

FINE FILTER AGGREGATE DETAIL

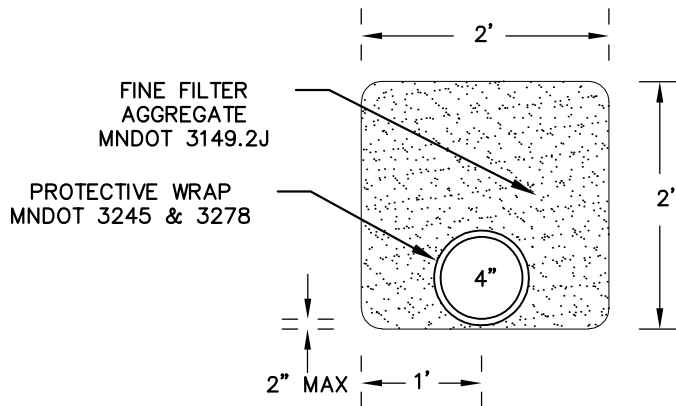

NOTES:

2" MAX. DEPTH OF FINE (OR COURSE) FILTER AGGREGATE AT ALL POINTS BELOW PIPE.

THE PIPE FOR BOTH INSTALLATIONS MUST BE A 4" OR 6" PERFORATED PIPE (SCH 40 PVC).

WHEN USING THE FINE FILTER AGGREGATE BASE THE 4" PIPE MUST HAVE A PROTECTIVE WRAP, MEETING MN/DOT 3245 AND 3278 SPECS.

WHEN USING THE COURSE FILTER AGGREGATE BASE THE TRENCH MUST BE LINED WITH TYPE I FILTER FABRIC MEETING MN/DOT SPEC. 3733



LAST REVISION
JANUARY 2021

PVC SUBDRAIN INTO LOW POINT CATCH BASIN (EXISTING CURB IN PLACE)

CITY OF MAPLE GROVE ENGINEERING
& PUBLIC WORKS DEPARTMENTS

STANDARD
PLATE #
STS-10